

# Up/Down Counter/Timer

## DIN size W72×H36mm, Indication only Counter/Timer

### Features

- Upgraded count speed : 5kps
- Wide range of input power supply :  
100–240VAC 50/60Hz, 12–24VDC (Option)
- Microprocessor controlled
- Selectable Counter or Timer function by internal DIP switch
- Selectable timing ranges



**⚠ Please read "Caution for your safety" in operation manual before using.**



### Ordering information

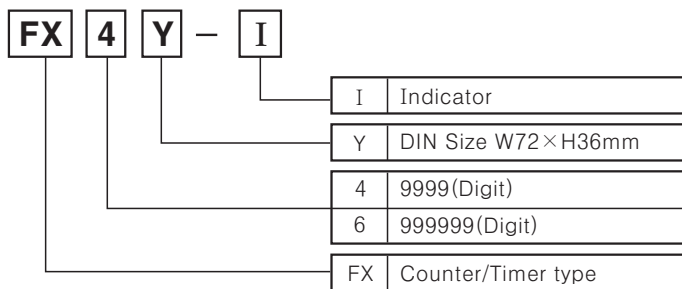

### Specifications

※ A blacked (■) item is upgraded function.

Model	FX4Y-I	FX6Y-I
Digit	4	6
Digit size	W8×H14mm	W4×H8mm
Power supply	100–240VAC 50/60Hz, 12–24VDC (Option)	
Allowable voltage range	90 ~ 110% of rated voltage	
Power consumption	Approx. 4.5VA(240VAC 60Hz), Approx. 2.5W(24VDC)	
<b>Max. counting speed</b>	<b>Selectable 30cps/5kps by internal DIP switch</b>	
Min. input signal width	INHIBIT input RESET input	Min. 20ms
Input	CP1, CP2 input RESET input	No voltage input⇒ Impedance at short-circuit : Max. 470Ω, Residual voltage at short-circuit : Max. 1VDC, Impedance at open-circuit : Min. 100kΩ
Memory retention	10years(When using non-volatile semiconductor memory)	
Power for external sensor	12VDC±10% 50mA Max.	
Insulation resistance	Min. 100MΩ (at 500VDC)	
Dielectric strength	2000VAC 50/60Hz for 1 minute	
Noise strength	AC Type	±2kV the square wave noise(pulse width:1μs) by the noise simulator
	DC Type	±500V the square wave noise(pulse width:1μs) by the noise simulator
Vibration	Mechanical	0.75mm amplitude at frequency of 10 ~ 55Hz in each of X, Y, Z directions for 1hour
	Malfunction	0.5mm amplitude at frequency of 10 ~ 55Hz in each of X, Y, Z directions for 10 minutes
Shock	Mechanical	300m/s <sup>2</sup> (Approx. 30G) in X, Y, Z directions for 3 times
	Malfunction	100m/s <sup>2</sup> (Approx. 10G) in X, Y, Z directions for 3 times
Ambient temperature	-10 ~ +55℃ (at non-freezing status)	
Storage temperature	-25 ~ +65℃ (at non-freezing status)	
Ambient humidity	35 ~ 85%RH	
Life cycle	semi-permanent	
Weight	AC type:Approx. 126g, DC type:Approx. 130g	AC type:Approx. 128g, DC type:Approx. 132g
Approval		

(A)  
Counter

(B)  
Timer

(C)  
Temp.  
controller

(D)  
Power  
controller

(E)  
Panel  
meter

(F)  
Tacho/  
Speed/  
Pulse  
meter

(G)  
Display  
unit

(H)  
Sensor  
controller

(I)  
Proximity  
sensor

(J)  
Photo  
electric  
sensor

(K)  
Pressure  
sensor

(L)  
Rotary  
encoder

(M)  
5-Phase  
stepping  
motor &  
Driver &  
Controller

# FXY Series

## Connections

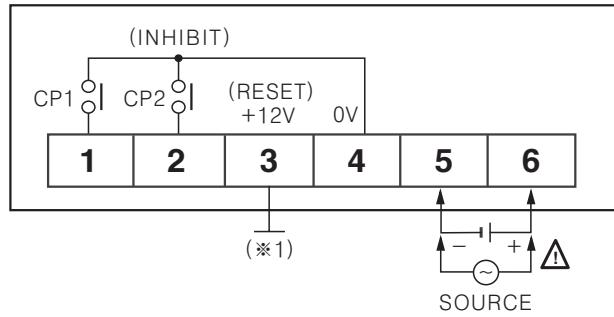

(※1) It can be selected reset or sensor power (+12VDC 50mA) by controlling internal jump pin.

(※2) CP1, CP2 : When using for counter

(※3) INHIBIT (CP2) : Time Hold terminal when using for timer (Connect S/W to ②+④ in exterior)

(※4) Operated by a Power ON Start method when it is used as a timer.

## Input connections

### ◎Solid-state input

- Standard input sensor : NPN universal output type sensor

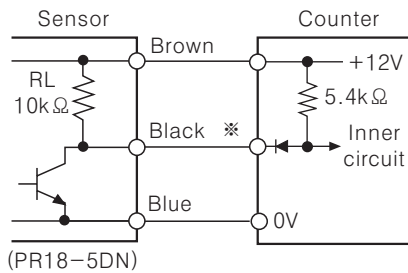

- Transistor ON → Counting
- NPN universal output type sensor

※CP1, CP2(INHIBIT), RESET input

### ◎Contact input

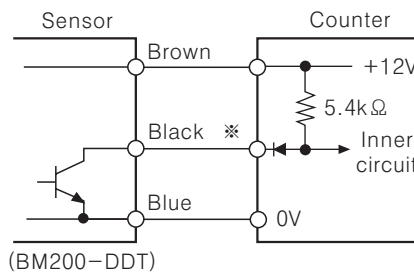

- Transistor ON → Counting
- NPN open collector output type sensor

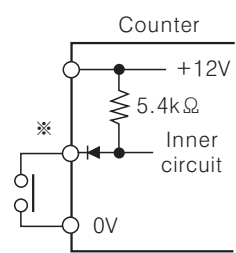

- Contact ON → Counting
- Limit S/W, Micro S/W
- Please use a reliable contacts

- Using PNP universal output type sensor

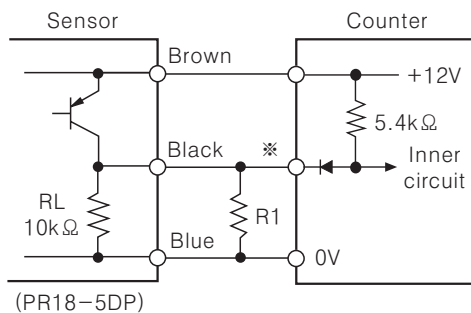

- Since PNP universal output type of sensors has high output impedance, please make sure to keep under condition.

: Please set R1 value to make the composed resistance of  $R_L + R_1$  is Max.  $470k\Omega$

※CP1, CP2(INHIBIT), RESET input

- Using PNP open collector output type sensor

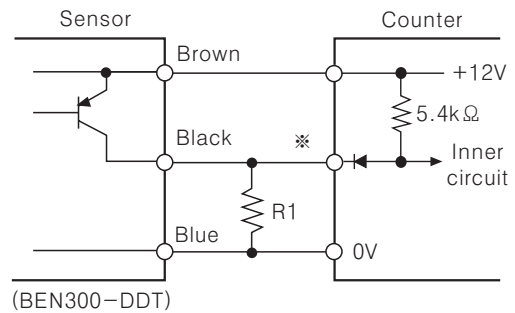

- In case of PNP open collector output type sensor, please connect lower than  $470\Omega$  of R1 to input terminal before using.

# Up/Down Counter/Timer

## ◎Counting method

Please take care of the selection of sensor because the counting method of NPN output type sensor is different from PNP output type sensor.

### ●NPN universal output type

: When the sensor changes OFF to ON, it is counting

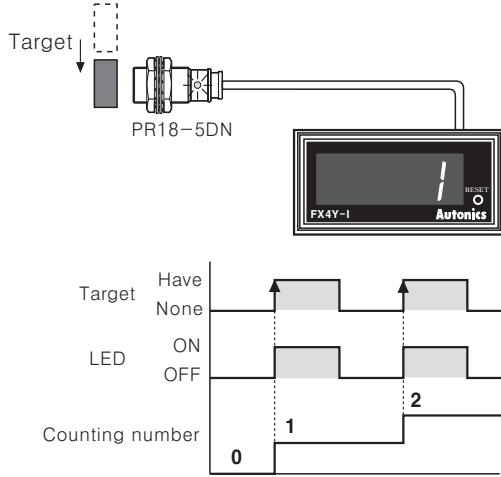

### ●PNP universal output type

: When the sensor changes ON to OFF, it is counting

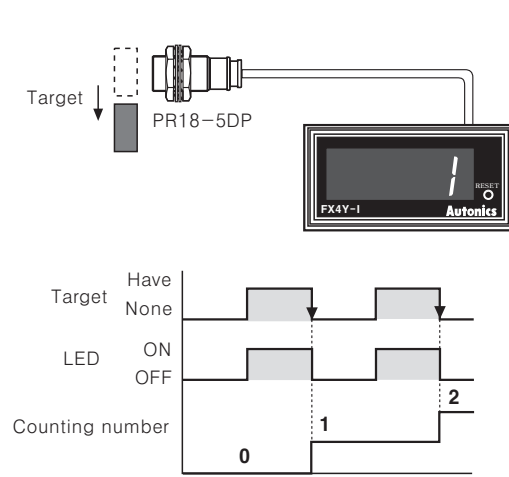

## ■Dimensions

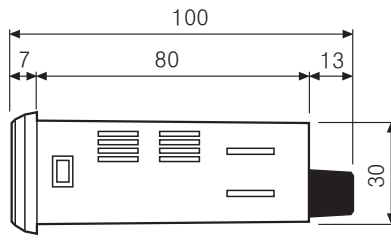
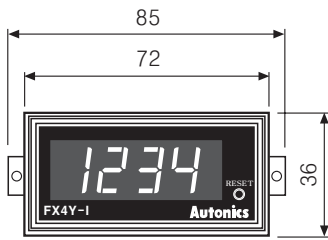

### ●Panel cut-out

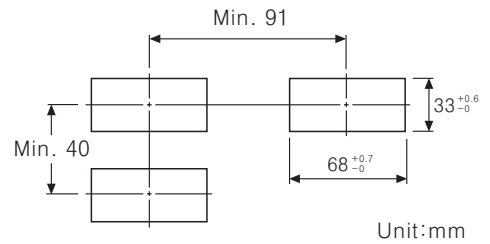

## ■Counting function

### ●Up mode

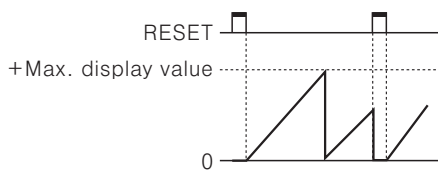

### ●Down mode

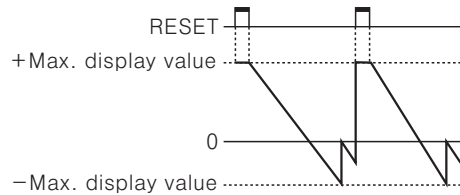

### ●Up/Down-A, B, C Mode

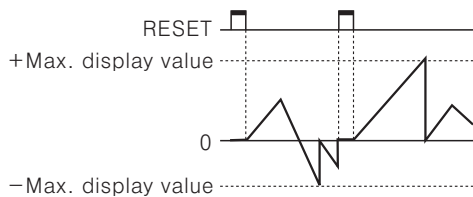

### ●Up/Down-D, E, F Mode

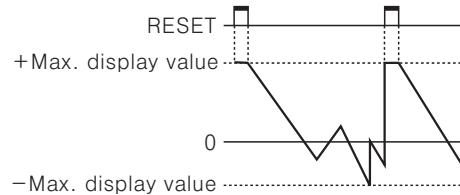

(A) Counter

(B) Timer

(C) Temp. controller

(D) Power controller

(E) Panel meter

(F) Tacho/ Speed/ Pulse meter

(G) Display unit

(H) Sensor controller

(I) Proximity sensor

(J) Photo electric sensor

(K) Pressure sensor

(L) Rotary encoder

(M) 5-Phase stepping motor & Driver & Controller

# FXY Series

## ■ Selection by DIP switches

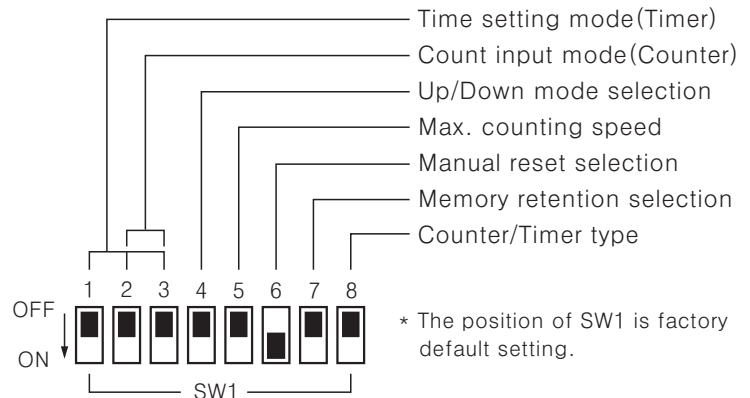
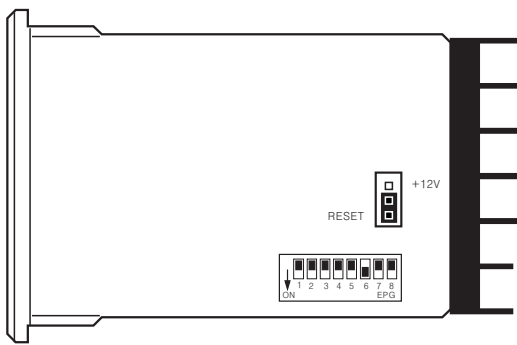

### ● Up/Down mode

SW1	Function
4 OFF <input type="checkbox"/> ON <input type="checkbox"/>	Up mode
OFF <input type="checkbox"/> ON <input type="checkbox"/>	Down mode

### ● Max. counting speed

SW1	CP1, CP2
5 OFF <input type="checkbox"/> ON <input type="checkbox"/>	30cps
OFF <input type="checkbox"/> ON <input type="checkbox"/>	<b>5kcps</b>

### ● Manual reset selection

SW1	Function
6 OFF <input type="checkbox"/> ON <input type="checkbox"/>	Reset switch disabled
OFF <input type="checkbox"/> ON <input type="checkbox"/>	Reset switch enabled

### ● Memory retention

SW1	Function
7 OFF <input type="checkbox"/> ON <input type="checkbox"/>	Memory
OFF <input type="checkbox"/> ON <input type="checkbox"/>	Power reset(No memory)

### ● Counter/Timer selection

SW1	Function
8 OFF <input type="checkbox"/> ON <input type="checkbox"/>	Timer
OFF <input type="checkbox"/> ON <input type="checkbox"/>	Counter

## ■ Time setting mode(Timer)

SW1	4Digit	6Digit	SW1	4Digit	6Digit
<b>A</b> OFF <input type="checkbox"/> ON <input type="checkbox"/>	<b>99.99sec</b>	<b>99999.9sec</b>	<b>E</b> OFF <input type="checkbox"/> ON <input type="checkbox"/>	<b>999.9min</b>	<b>99999.9min</b>
<b>B</b> OFF <input type="checkbox"/> ON <input type="checkbox"/>	<b>999.9sec</b>	<b>999999sec</b>	<b>F</b> OFF <input type="checkbox"/> ON <input type="checkbox"/>	<b>99hour 59min</b>	<b>99hour 59min 59sec</b>
<b>C</b> OFF <input type="checkbox"/> ON <input type="checkbox"/>	<b>9999sec</b>	<b>99min 59.99sec</b>	<b>G</b> OFF <input type="checkbox"/> ON <input type="checkbox"/>	<b>999.9hour</b>	<b>9999hour 59min</b>
<b>D</b> OFF <input type="checkbox"/> ON <input type="checkbox"/>	<b>99min 59sec</b>	<b>999min 59.9sec</b>	<b>H</b> OFF <input type="checkbox"/> ON <input type="checkbox"/>	<b>9999hour</b>	<b>99999.9hour</b>

# Up/Down Counter/Timer

## Input mode(Counter)

Input mode(SW1)		4 OFF <input type="checkbox"/> ON <input checked="" type="checkbox"/> <b>Up mode</b>	Input mode(SW1)	4 OFF <input type="checkbox"/> ON <input checked="" type="checkbox"/> <b>Down mode</b>
Up/Down-A Command input	OFF <input type="checkbox"/> ON <input checked="" type="checkbox"/>		Up/Down-D Command input	
	OFF <input type="checkbox"/> ON <input checked="" type="checkbox"/>			Up/Down-B Individual input
Up/Down-C Phase difference input	OFF <input type="checkbox"/> ON <input checked="" type="checkbox"/>		Up/Down-F Phase difference input	
	OFF <input type="checkbox"/> ON <input checked="" type="checkbox"/>			Up input
<b>Up input</b>	OFF <input type="checkbox"/> ON <input checked="" type="checkbox"/>		<b>Down input</b>	
	OFF <input type="checkbox"/> ON <input checked="" type="checkbox"/>			Down input

(A) Counter

(B) Timer

(C) Temp. controller

(D) Power controller

(E) Panel meter

(F) Tacho/Speed/Pulse meter

(G) Display unit

(H) Sensor controller

(I) Proximity sensor

(J) Photo electric sensor

(K) Pressure sensor

(L) Rotary encoder

(M) 5-Phase stepping motor & Driver & Controller

※ Ⓐ : Over Min. signal width, Ⓑ : Over 1/2 of Min. signal width.

Counting miss by one(±) is occurred if the signal width of Ⓐ or Ⓑ is less than Min. signal width.

※ n : + Max.display value(FX4Y-I : 9999, FX6Y-I : 999999)

# FXY Series

## ■ Proper usage

### ◎ Reset

#### ● Reset

When select a reset input/output mode again, after applying power, please reset or reset manually.

**Otherwise it previous mode will be operating.**

#### ● The reset signal width

It is reset perfectly when the reset signal is applied for **max. 20ms** regardless of the contact input & solid-state input.

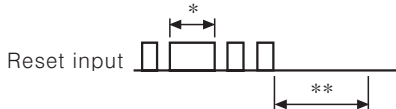

\*In case of a contact reset, it is reset perfectly if the ON time of reset signal is applied for max. 20ms even though a chattering is occurred.

\*\*Signal input (Cp1, Cp2) is possible if there is no reset input for min. 50ms after reset input.

### ◎ Min. signal width

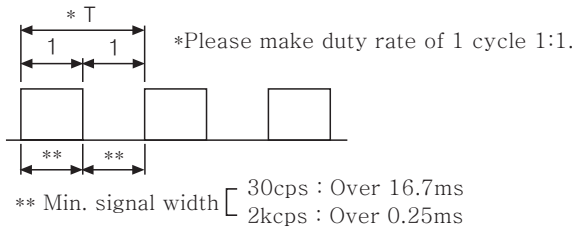

### ◎ Maximum counting speed

This is respond speed per 1 sec. when the duty rate (ON/OFF) of input signal is 1:1 if duty rate is not 1:1, the respond speed will be getting slow against input signal and also the width between ON and OFF should be over min. signal width.

And one of ON width and OFF width is under min. signal width, this product may not response.

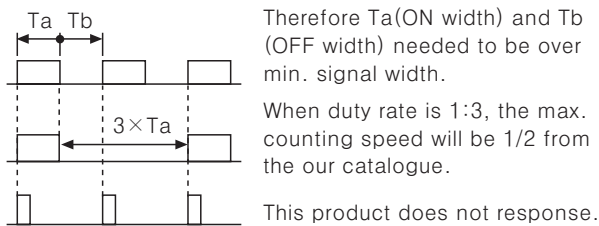

### ◎ Detach the case from body

While pushing the lock equipment with with driver to the way of front, push the terminal block.

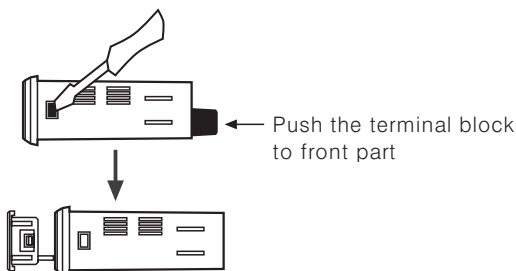

### ◎ Using inner pin

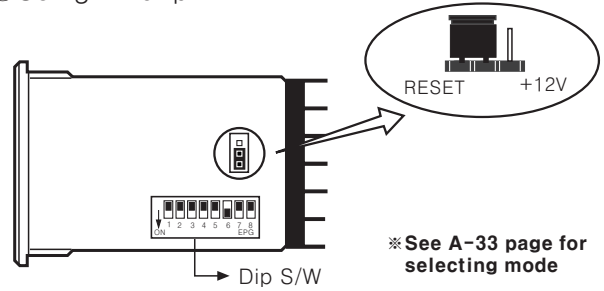

### ● When using terminal 3 for external reset terminal

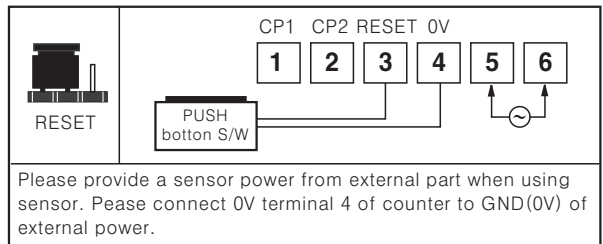

### ● When using terminal 3 for sensor power terminal

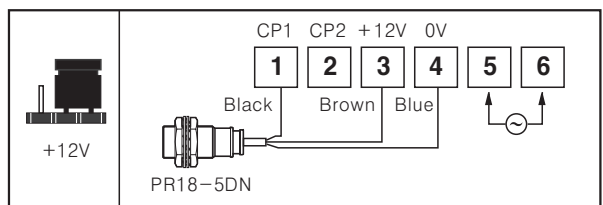

### ◎ INHIBIT Only timer

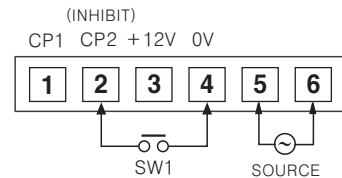

- It becomes the INHIBIT mode when SW1 turns on. (Time Hold)
- In case of stopping time at a moment while the timer is progressing, the Inhibit mode can be used.
- When the Inhibit input is cut off, time is progressing again.

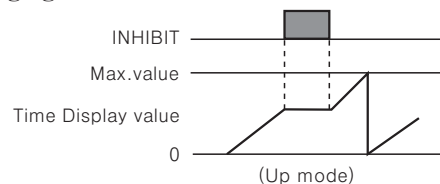

### ◎ Power

The inner circuit voltage starts to rise up for the first 100ms after power on, the input may not work at this time. And also the inner circuit voltage drops down for the last 500ms after power off, the input may not work at this time.

